



## OPERATION

The Ruelco 2-way ESD manual valve is a normally closed valve which will open the inlet to vent when the knob is pulled. Its high flow rate and two way pull to open action make it ideal for use in manual ESD systems and other control applications that require a fast response time. The supply pressure acting on the unbalance stem maintains the valve in the closed position. This prevents vibration or small pulling forces from accidentally opening the valve. Once pulled, the valve will stay in the open position until manually closed.

## FEATURES

- 316 stainless steel construction (models to N.A.C.E. MR0175 available)
- Large Cv factor assures fast system response
- May be used in pneumatic or hydraulic systems
- Viton seals are utilized for dependability
- Easily repaired without removing valve from panel
- Threaded vent port allows use of a vent screen

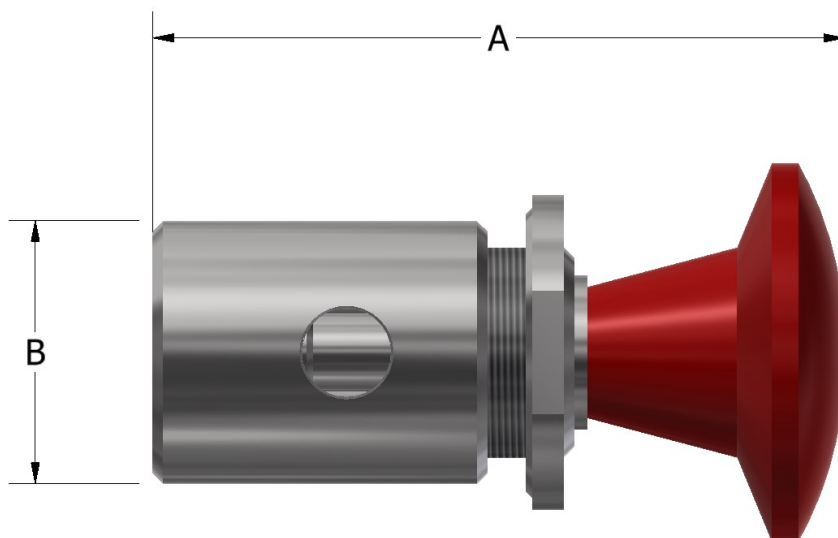

2-WAY ESD VALVE

## DIMENSIONS

A (OPEN / CLOSED)	3.75 / 3.25" (95.25 / 82.55 mm)
B	1.25" (31.8 mm)
CONNECTION PORT SIZES	1/4" FNPT
PANEL MOUNT HOLE	1.00" (25.4 mm)
MAXIMUM PANEL THICKNESS	.25" (6.4 mm)
WEIGHT	12 OZ (.340 kg)

PHONE: 504-340-0055  
FAX: 504-340-0056  
EMAIL: SALES@RUELCO.COM

1209 DISTRIBUTORS ROW  
NEW ORLEANS, LA 70123



Proudly Distributed By

**TRIDENT** AUSTRALIA  
FLUID SYSTEMS & COMPONENTS

## PARTS LIST

ITEM	QUANTITY	DESCRIPTION	MATERIAL
1	1	RED KNOB	PHENOLIC
2	1	PANEL MOUNT NUT	316 ST. STL.
3	1	FLAT WASHER	316 ST. STL.
4*	1	STEM SEAL	FLUOROCARBON
5	1	BODY	316 ST. STL.
6	1	STEM	316 ST. STL.
7*	1	BODY SEAL	FLUOROCARBON
8	1	VENT SCREEN (OPTIONAL)	316 ST. STL.

\* INDICATES ITEMS IN THE REPAIR KIT

## SPECIFICATIONS

MAXIMUM WORKING PRESSURE	150 PSI (10.3 BAR)
AMBIENT TEMPERATURE RANGE	-20 TO 250° F -29 TO 122° C
Cv FACTOR	1.8

## REPAIR KIT

- 11-005-000

OTHER TEMPERATURE RANGES AND SEAL COMPOUNDS AVAILABLE UPON REQUEST

## ORDERING CODE

**1102 X 241 X R**

BASE MODEL NUMBER

Standard Corrosive Service -- (-)  
N.A.C.E. option ----- N

0 --- Without Vent Screen  
S --- With Vent Screen

**2-WAY ESD VALVE**

PHONE: 504-340-0055  
FAX: 504-340-0056  
EMAIL: SALES@RUELCO.COM

1209 DISTRIBUTORS ROW  
NEW ORLEANS, LA 70123



## OPERATION

The Ruelco 2-way High Pressure ESD manual valve is a normally closed valve which will open the inlet to vent when the knob is pulled. Its high flow rate and two way pull to open action make it ideal for use in manual ESD systems and other control applications that require a fast response time. The supply pressure acting on the unbalance stem maintains the valve in the closed position. This prevents vibration or small pulling forces from accidentally opening the valve. Once pulled, the valve will stay in the open position until manually closed.

## FEATURES

- 316 stainless steel construction (models to N.A.C.E. MR0175 available)
- Large Cv factor assures fast system response
- Ideal for high pressure pneumatic or hydraulic systems
- O-ring seals are utilized for dependability
- Easily repaired without removing valve from panel
- Threaded vent port allows use of a vent screen

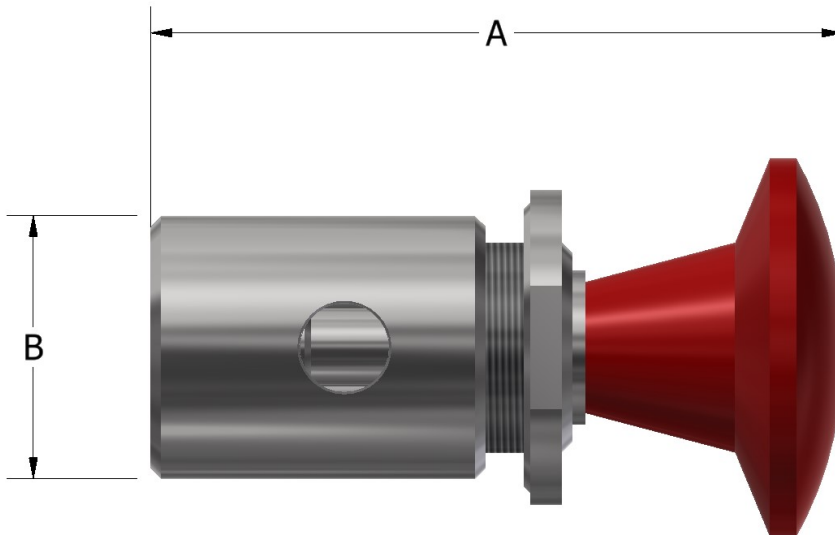

2-WAY HIGH PRESSURE ESD VALVE

## DIMENSIONS

A (OPEN / CLOSED)	3.75 / 3.25" (95.25 / 82.55 mm)
B	1.25" (31.8 mm)
CONNECTION PORT SIZES	1/4" FNPT
PANEL MOUNT HOLE	1.00" (25.4 mm)
MAXIMUM PANEL THICKNESS	.25" (6.4 mm)
WEIGHT	12 OZ (.340 kg)

PHONE: 504-340-0055  
FAX: 504-340-0056  
EMAIL: SALES@RUELCO.COM

1209 DISTRIBUTORS ROW  
NEW ORLEANS, LA 70123



Proudly Distributed By

**TRIDENT** AUSTRALIA  
FLUID SYSTEMS & COMPONENTS

## PARTS LIST

ITEM	QUANTITY	DESCRIPTION	MATERIAL
1	1	RED KNOB	PHENOLIC
2	1	PANEL MOUNT NUT	316 ST. STL.
3	1	FLAT WASHER	316 ST. STL.
4*	1	STEM SEAL	FLUOROCARBON
5	1	BODY	316 ST. STL.
6	1	STEM	316 ST. STL.
7*	1	BODY SEAL	URETHANE
8	1	VENT SCREEN (OPTIONAL)	316 ST. STL.

\* INDICATES ITEMS IN THE REPAIR KIT

## SPECIFICATIONS

MAXIMUM WORKING PRESSURE	1,000 PSI (68.9 BAR)
AMBIENT TEMPERATURE RANGE	-20 TO 250° F -29 TO 122° C
Cv FACTOR	1.8

## REPAIR KIT

- 11-005-0H0

OTHER TEMPERATURE RANGES AND SEAL COMPOUNDS AVAILABLE UPON REQUEST

## ORDERING CODE

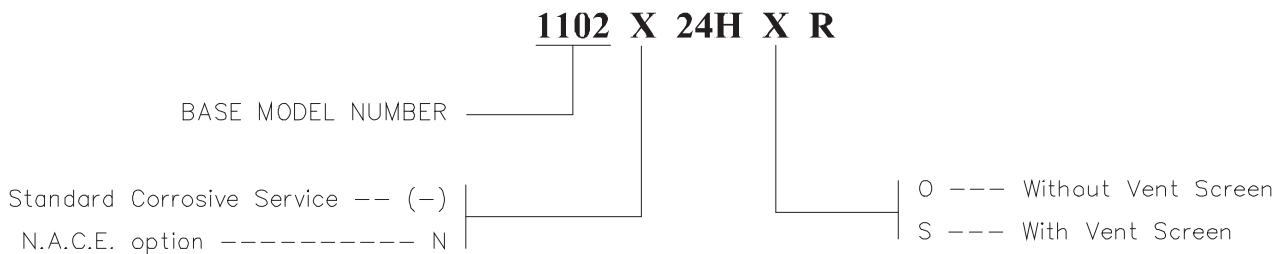

**2-WAY HIGH PRESSURE ESD VALVE**

PHONE: 504-340-0055  
FAX: 504-340-0056  
EMAIL: SALES@RUELCO.COM

1209 DISTRIBUTORS ROW  
NEW ORLEANS, LA 70123



## OPERATION

The Ruelco 3-way High Pressure ESD manual valve is a normally open valve which will allow In to Out flow. When the knob is pulled, the inlet will be blocked and the outlet pressure will flow to the vent port. It's high flow rate make it ideal for use in manual ESD systems and other control applications that require a fast response time. The supply pressure acting on the unbalance stem maintains the valve in the closed position. This prevents vibration or small pulling forces from accidentally opening the valve. Once pulled, the valve will stay in the open position until manually closed.

## FEATURES

- 316 stainless steel construction (models to N.A.C.E. MR0175 available)
- Large Cv factor assures fast system response
- Ideal for high pressure pneumatic or hydraulic systems
- O-ring seals are utilized for dependability
- Easy repaired without removing valve from panel
- Threaded vent port allows use of a vent screen

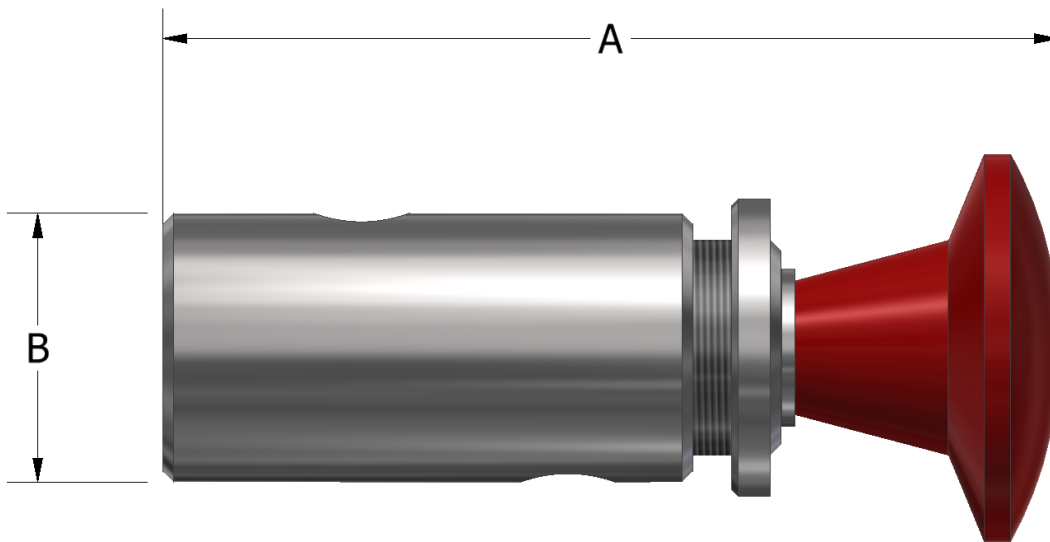

**3-WAY ESD VALVE**

## DIMENSIONS

A (OPEN / CLOSED)	4.61 / 4.11" (117.1 / 104.4 mm)
B	1.25" (31.8 mm)
CONNECTION PORT SIZES	1/4" FNPT
PANEL MOUNT HOLE	1.00" (25.4 mm)
MAXIMUM PANEL THICKNESS	.25" (6.4 mm)
WEIGHT	16 OZ (.465 kg)

PHONE: 504-340-0055  
FAX: 504-340-0056  
EMAIL: SALES@RUELCO.COM

1209 DISTRIBUTORS ROW  
NEW ORLEANS, LA 70123



Proudly Distributed By

**TRIDENT** AUSTRALIA  
FLUID SYSTEMS & COMPONENTS

## PARTS LIST

ITEM	QUANTITY	DESCRIPTION	MATERIAL
1	1	RED KNOB	PHENOLIC
2	1	FLAT WASHER	316 ST. STL.
3	1	PANEL MOUNT NUT	316 ST. STL.
4*	2	STEM SEAL	FLUOROCARBON
5	1	BODY	316 ST. STL.
6	1	STEM	316 ST. STL.
7*	1	BODY SEAL	FLUOROCARBON
8	1	VENT SCREEN (OPTIONAL)	316 ST. STL.

\* INDICATES ITEMS IN THE REPAIR KIT

## SPECIFICATIONS

MAXIMUM WORKING PRESSURE	150 PSI (10.3 BAR)
AMBIENT TEMPERATURE RANGE	-20 TO 250° F -29 TO 122° C
Cv FACTOR	1.8

## REPAIR KIT

- 11-005-3WY

OTHER TEMPERATURE RANGES AND SEAL COMPOUNDS AVAILABLE UPON REQUEST

**3-WAY ESD VALVE**

## ORDERING CODE

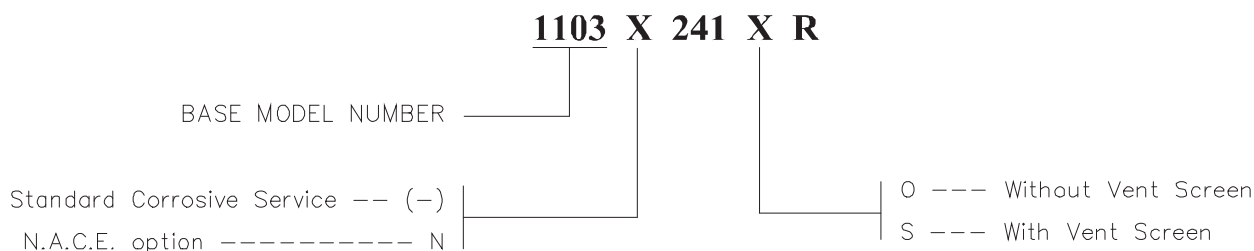

PHONE: 504-340-0055  
FAX: 504-340-0056  
EMAIL: SALES@RUELCO.COM

1209 DISTRIBUTORS ROW  
NEW ORLEANS, LA 70123



Proudly Distributed By

**TRIDENT AUSTRALIA**  
FLUID SYSTEMS & COMPONENTS

## OPERATION

The Ruelco ESD station is a compact, highly visible ESD station. It uses the Ruelco 2-way or 3-way, high flow, manual pull valve to quickly shut down any pneumatic or hydraulic loop system. The Ruelco ESD station also uses a large red tag to increase visibility. It can be mounted in any desired location by clamping the station to any 1-1/2" diameter handrail or any 1-1/2" diameter pipe. When the manual valve is pulled open, it will stay open until it is manually pushed closed.

## FEATURES

- 316 stainless steel construction (models to N.A.C.E. MR0175 available)
- Large Cv factor assures fast system response
- May be used in pneumatic or hydraulic systems
- Viton seals are utilized for dependability
- Easily repaired without removing valve from station mounting plate

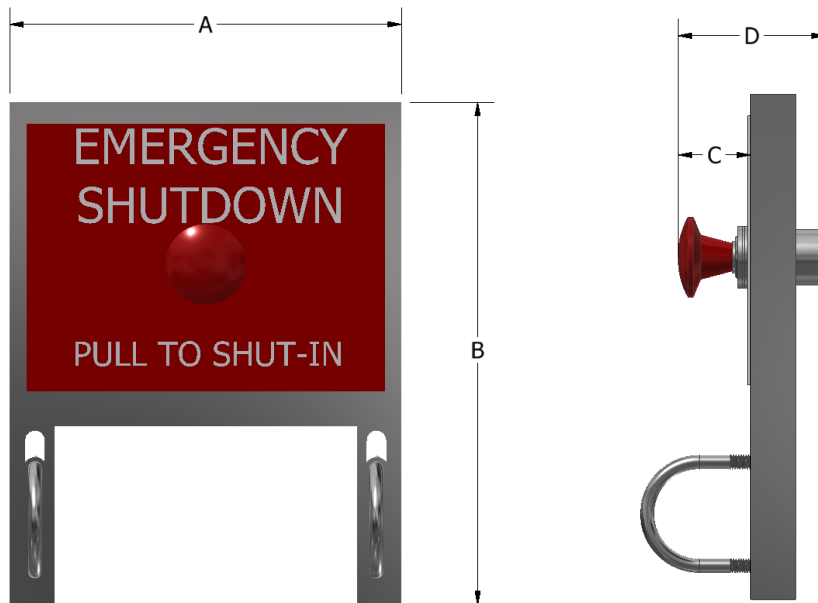

## DIMENSIONS

A	8.75" (222.3 mm)
B	11.25" (285.8 mm)
C (OPEN / CLOSED)	1.62 / 2.12" (41.1 / 53.8 mm)
D (2-WAY VALVE)	3.25" (82.55 mm)
D (3-WAY VALVE)	4.11" (104.4 mm)

PHONE: 504-340-0055  
FAX: 504-340-0056  
EMAIL: SALES@RUELCO.COM

1209 DISTRIBUTORS ROW  
NEW ORLEANS, LA 70123

ESD STATION



Proudly Distributed By

**TRIDENT** AUSTRALIA  
FLUID SYSTEMS & COMPONENTS

## PARTS LIST

ITEM	QUANTITY	DESCRIPTION	MATERIAL
1	1	FACE PLATE	ACRYLIC
2	1	ESD VALVE	316 ST. STL.
3	2	U-BOLT	316 ST. STL.
4	4	FLAT WASHER	316 ST. STL.
5	4	HEX NUT	316 ST. STL.
6	1	SUPPORT BRACKET	316 ST. STL.

## SPECIFICATIONS

MAXIMUM WORKING PRESSURE	150 PSI (10.3 BAR)
AMBIENT TEMPERATURE RANGE	-20 TO 250° F -29 TO 122° C
Cv FACTOR	1.8

## REPAIR KIT

- 11-005-000 - 2-WAY VALVE
- 11-005-3WY - 3-WAY VALVE

OTHER TEMPERATURE RANGES AND SEAL COMPOUNDS AVAILABLE UPON REQUEST

## ORDERING CODE

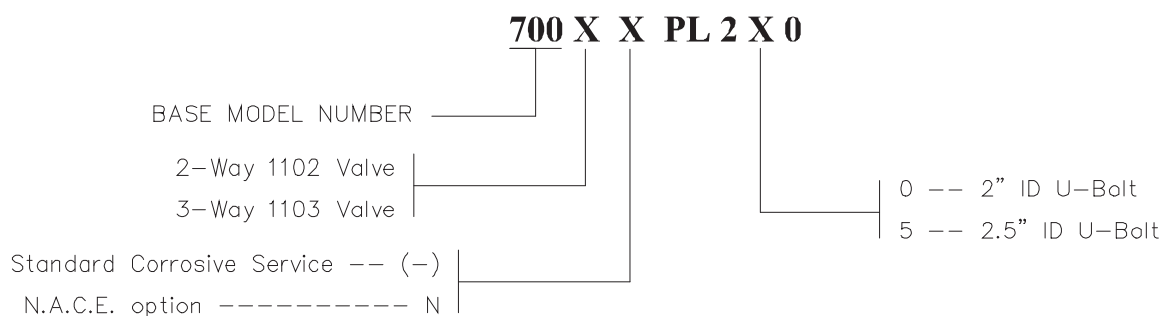

ESD STATION

PHONE: 504-340-0055  
FAX: 504-340-0056  
EMAIL: SALES@RUELCO.COM

1209 DISTRIBUTORS ROW  
NEW ORLEANS, LA 70123